

See discussions, stats, and author profiles for this publication at: <https://www.researchgate.net/publication/224664835>

# RF feedback for beam loading compensation in the SLC Damping Rings

Conference Paper · June 1993

DOI: 10.1109/PAC.1993.309325 · Source: IEEE Xplore

CITATIONS

6

READS

21

6 authors, including:



[Michiko G Minty](#)

Brookhaven National Laboratory

253 PUBLICATIONS 1,679 CITATIONS

[SEE PROFILE](#)



[Flemming Pedersen](#)

CERN

89 PUBLICATIONS 464 CITATIONS

[SEE PROFILE](#)

Some of the authors of this publication are also working on these related projects:



Run Coordinator for FY17 255 GeV RHIC Polarized Proton Run [View project](#)

# RF Feedback for Beam Loading Compensation in the SLC Damping Rings\*

P.Krejčík, P.Corredoura, M.Minty, R.Siemann, R.Tighe  
Stanford Linear Accelerator Center  
Stanford University, Stanford, California 94305

F.Pedersen  
CERN, CH-1211 Switzerland

## Abstract

An RF feedback around the cavities and klystron has been added to the SLC Damping Rings to provide stability under changing beam loading conditions. The beam loading changes in the cavity as a result of programming the RF voltage during the beam store time. The RF voltage is lowered to control the onset of bunch length instabilities, but without RF feedback the beam becomes unstable in the Robinson zero frequency mode. The steady state analysis of the beam loading with and without feedback is presented together with a description of the hardware implementation. Operational experience with the system during SLC running is described.

## I. INTRODUCTION

The RF system for the SLC damping rings comprises one 60 kW klystron per ring, driving two two-cell cavities through a circulator and a magic-T. At a constant RF voltage totaling 1 MV nominally for the ring, the degree of RF over-coupling is optimized for RF matching of the klystron to the combined RF load of the cavity and beam at the design intensity of two bunches of  $5 \cdot 10^{10}$  particles each. In order to control the onset of turbulent bunch lengthening and the associated "sawtooth" instability it is desirable to program the RF voltage during the beam store time[1]. The RF voltage is ramped down to a low value shortly after injection to prevent the bunch length from damping below the instability threshold.

We found that, when two bunches were present in the ring, it was not possible to ramp the voltage down without a beam loading or "Robinson like" instability occurring. This arises because the cavities are tuned for an optimum loading angle of zero when the voltage is at its maximum, but are then far from

optimum at low voltages. With the cavity tuning angle fixed during the beam store time the beam rapidly goes unstable as the condition is reached where the beam power exceeds the cavity dissipation power.

To overcome this limitation we have implemented a direct RF feedback system of a type also used in other beam loading dominated accelerators[2,3]. This feedback compensates the cavity loading to the extent of the maximum gain permitted in the feedback system and has allowed the programmable voltage ramp to operate down to much lower levels.

## II. BEAM LOADING STABILITY CRITERIA

The stability analysis of the cavity and klystron with beam is based upon a model of the cavity as a resonator with a fundamental mode only, and driven by two current sources representing the generator (the klystron) and the beam, fig. 1. Using the notation in reference [5], these currents can be represented as phasors, as in fig. 2. The impedance angle,  $\phi_Z$ , is determined by the cavity geometry, i.e. the frequency to which the cavity is tuned w.r.t. the RF. The beam phase angle,  $\phi_B$ , is determined by the synchronous phase condition for the particle. In practice, we tune the cavity on the basis of the measured loading angle,  $\phi_L$ , between the klystron current and the cavity voltage. The cavity tune that results will thus be a function of the beam current,  $I_B$ , and the generator current,  $I_G$ , supplied by the klystron.

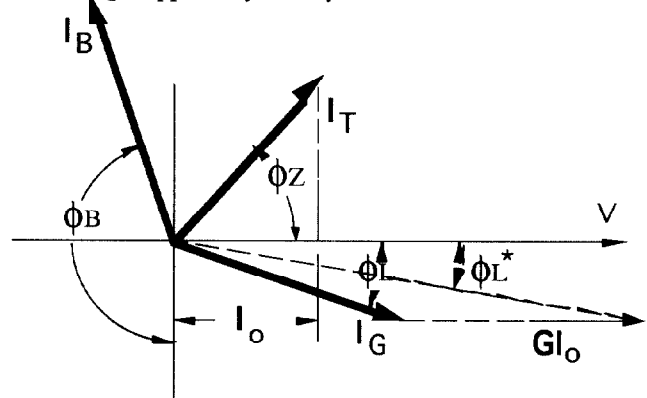

Fig. 2. The current from the generator, the beam and the total current are represented as phasors, referenced to the cavity voltage. The feedback contributes a term  $G I_0$ .

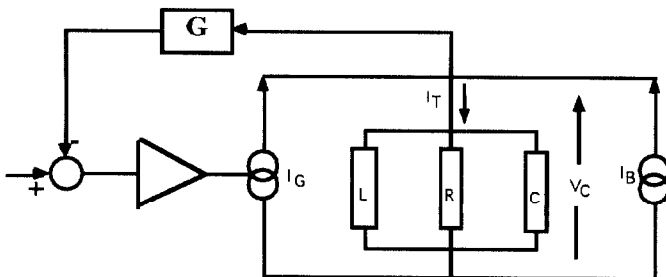

Fig. 1. Simple resonant cavity model driven by a generator and a beam current. RF feedback appears as a transform G of the cavity voltage summed with the klystron drive signal.

The beam loading ratio is defined as  $Y = I_B / I_0$ , where  $I_0$  is the real part of the total current in the cavity,  $I_T$ , i.e. the component of  $I_T$  in phase with the cavity voltage, V. The

\* Work supported by Department of Energy Contract DE-AC03-76SF00515.

vector relationship between these phasors can be described by the following:

$$I_G = \frac{I_0(1 + Y \sin \phi_B)}{\cos \phi_L} \quad (1)$$

$$\tan \phi_L = \frac{\tan \phi_Z - Y \cos \phi_B}{1 + Y \sin \phi_B} \quad (2)$$

The stability criterion derived by Robinson[4] can be expressed[5] as:

$$\frac{2 \cos \phi_B}{Y} < \sin 2\phi_Z < 0 \quad (3)$$

These stability boundaries are shown graphically in fig. 3, where the shaded region for positive  $\phi_Z$  leads to antidamping of the synchrotron oscillations of the bunches; and the left hand shaded region corresponds to unstable exponential growth as the beam loading limit is exceeded. The actual working point on this diagram is determined by the choice of loading angle. Superimposed on fig. 3 is a curve, derived from eqn (2) representing the locus of points for which we choose  $\phi_L$  to be zero, indicating how  $\phi_Z$  must change for increasing beam loading. These curves are calculated for our nominal 1 MV RF voltage for which the synchronous phase is close to  $170^\circ$ .

If the voltage is ramped down to 250 kV during the store the synchronous phase changes to  $140^\circ$  and the stability limit drops as shown by the lighter shaded region in fig. 3. In our particular mode of operation the cavity tune stays constant as the voltage is ramped down. For an intensity of  $2 \times 3.5 \cdot 10^{10}$  eqn (2) indicates that the loading angle changes to  $36^\circ$  as the voltage is ramped from 1 MV to 250 kV. The curve for  $\phi_L = 36^\circ$  in fig. 3 confirms that we are far beyond the limits of stability with our fixed cavity tune. The ramp occurs on a time scale of milliseconds during which it is impossible to retune the cavity back to a more favorable loading angle. Instead we reestablish stability by implementing direct RF feedback through the klystron.

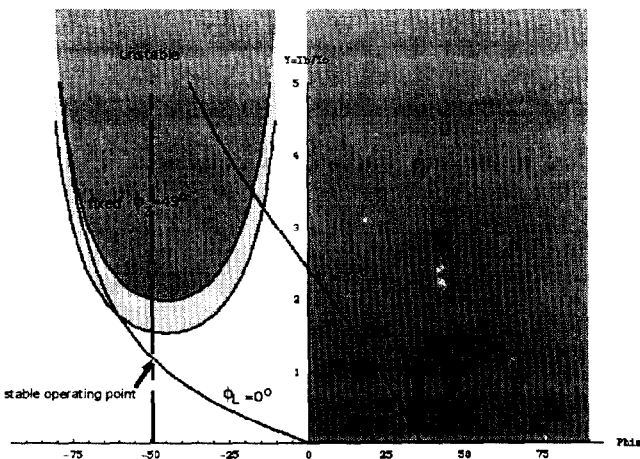

Fig. 3. Beam loading stability limit vs. impedance angle.

### III. DIRECT RF FEEDBACK: GAIN VS. STABILITY

Direct RF feedback requires feeding back a portion of the cavity voltage and summing it with the drive signal to the klystron. The group delay around this loop determines the

maximum gain at which the loop can operate stably. To see this we look at the transformed impedance of the cavity plus feedback. The complex impedance of the resonator in fig. 1, tuned to a frequency  $\omega_n$  and with a loaded quality factor  $Q_L$  and shunt impedance  $R_{SH}$ , is:

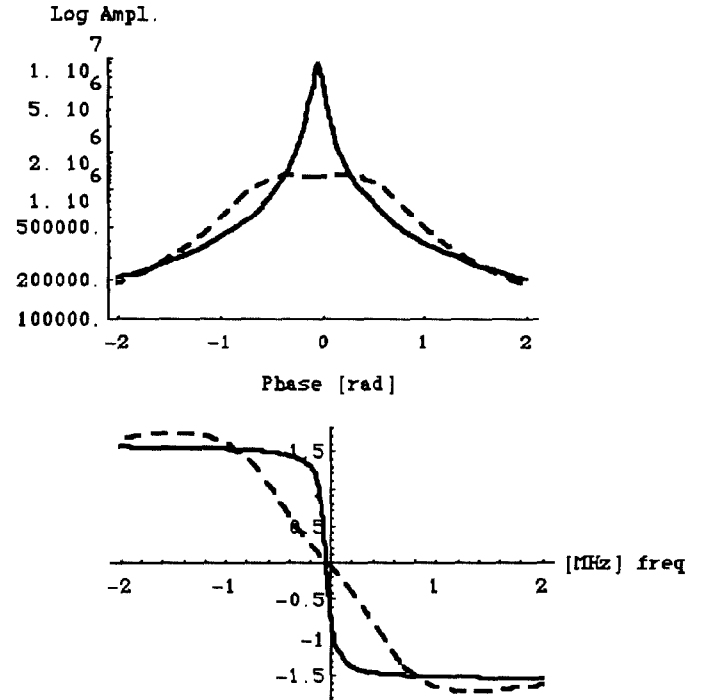

Fig. 4. Modelled phase and amplitude for the cavity impedance, with (dashed) and without (solid) feedback.

$$Z(j\omega) = \frac{j\omega \cdot \omega_n \cdot R_{SH} / Q_L}{(j\omega)^2 + j\omega \cdot \omega_n / Q_L + \omega_n^2} \quad (4)$$

This impedance function is shown in fig. 4 for our damping ring parameters.

The feedback transfer function,  $G(j\omega)$ , is given the product of a gain  $G_0$  with a transductance  $1/R_{SH}$  and a delay  $\Delta T$ :

$$G(j\omega) = \frac{G_0}{R_{SH}} \cdot e^{-j\omega\Delta T} \quad (5)$$

The closed loop transfer function gives the impedance of the cavity plus feedback, as seen by the beam:

$$Z'(j\omega) = \frac{Z(j\omega)}{1 + G(j\omega)Z(j\omega)} \quad (6)$$

which is also plotted in fig. 4 for a group delay of 300 nS and a gain  $G_0 = 6$ .

At the cavity frequency,  $\omega_n$ , we have  $Z(j\omega_n) = R_{SH}$  and  $G(j\omega_n) = G_0/R_{SH}$  so that the effective impedance is reduced as  $Z' = Z/(1+G_0)$ . The real part of the cavity current,  $I_0$ , increases by  $(1+G_0)$ . The effect on our stability diagram in fig. 3 is to raise the boundary of the shaded, left hand zone by the amount  $(1+G_0)$ .

The effective impedance can not be reduced indefinitely by increasing the gain  $G_0$ , as can be seen by applying the Nyquist

criterion to the magnitude of the open loop transfer function, which is required to be greater than -1,

$$|G(j\omega)Z(j\omega)| < 1 \tag{7}$$

Allowing for a 45° phase margin this leads to the limit:

$$1 + G_o < \frac{\pi Q_L}{2\omega_n \Delta T} \tag{8}$$

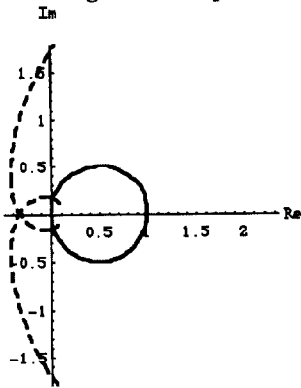

Fig. 5. Nyquist plot for the cavity impedance in fig. 4, illustrating the stability limit with feedback (dashed).

#### IV. DIRECT RF FEEDBACK IMPLEMENTATION

The klystron is located in the vault with the RF cavities so the signal path lengths are reasonably short for the feedback loop. The layout is shown schematically in fig. 5. The cavities have a two-cell structure which have a non-accelerating 0-mode close in frequency to the accelerating  $\pi$ -mode of the cavities. The cavity probe signals from the two cells are therefore combined with phase shifters and attenuators to ensure there is not excessive gain at the unwanted mode. The signals from the two cavities are further combined with appropriate phase shift and attenuation. A common phase shifter and attenuator in the loop is remotely operable through the SLC control system to tune the loop in the presence of beam. The measured open and closed loop response of the loop are shown in fig. 6.

#### V. PERFORMANCE WITH BEAM

The optimum setting for the feedback phase shifter is found empirically by observing the beam stability. Typically, an upper and a lower setting of the phase shifter will be found at which the beam is barely stable allowing us to find the midpoint of the stable range. In our analysis above, changing the phase shifter corresponds to a rotation about the origin of the dashed Nyquist curve in fig. 5. As the curve rotates it soon intercepts the stability boundary at -1. Increasing the gain  $G_o$  translates the curve to the left so we find that there is less range for rotation before hitting the boundary. As the stability constraint for the maximum gain depends on  $\Delta T$  in eqn (8), we have worked on improving the contribution to the group delay from the klystron. This was done by changing the klystron cavities for broader bandwidth, at the expense of a reduced klystron gain.

With RF feedback it is now possible to operate the damping ring comfortably with a ramp from 1 MV down to 250 kV with a beam intensity of two bunches of  $3.5 \cdot 10^{10}$  particles per bunch. This enhancement to the beam loading limitation in the rings is consistent with the predicted analysis above.

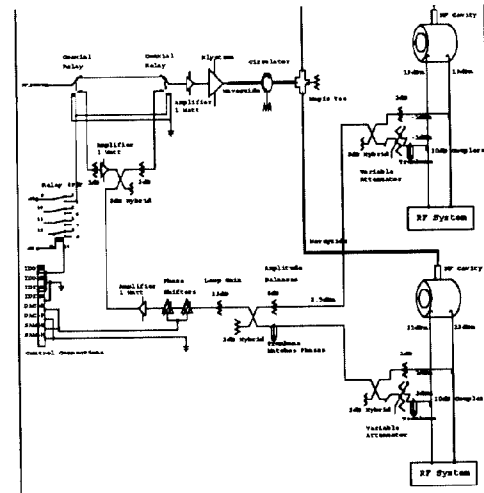

Fig. 5 Schematic of the direct RF feedback implemented around the klystron and two damping ring cavities.

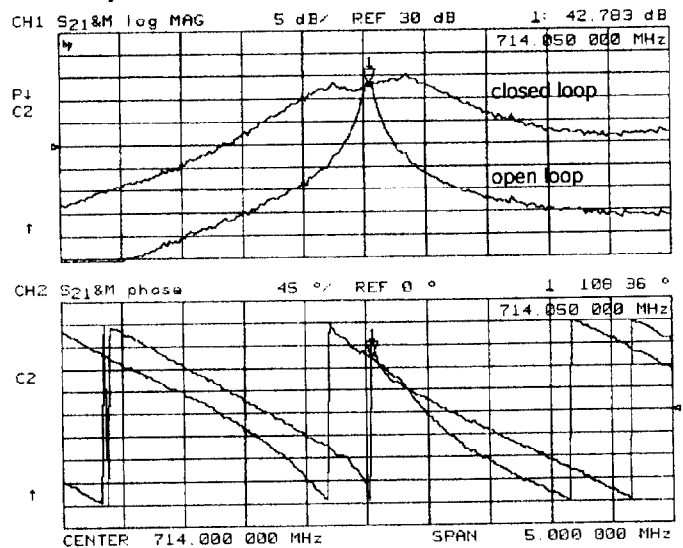

Fig. 6. Measured open and closed loop response of the system.

The limitations imposed by saturation effects of the klystron have not been discussed here. If the program gap voltage is too high for any given current the nonlinearity of the klystron drives the loop unstable.

The reduction in effective cavity impedance also reduces the damping rate of 0-mode dipole bunch oscillations, so some additional feedback is called for to damp injection transients.

#### VI. REFERENCES

- [1] P. Krejcik et al, "High Intensity Bunch Length Instabilities in the SLC Damping Rings", These proceedings.
- [2] F. Pedersen IEEE Trans. Nucl. Sci. NS-32, p.2138, 1985.
- [3] D. Boussard IEEE Trans. Nucl. Sci. NS-32, p.1852, 1985.
- [4] K.W. Robinson CEA Report no. CEAL-1010, 1964.
- [5] F. Pedersen IEEE Trans. Nucl. Sci. NS-22, p.1906, 1975.