

Modulation and Detection

John Staples, LBNL
November 2007

Linear Sum of Two Signals

Equation of sinusoidally-varying voltage: $V(t) = V_0 \cos(\omega_0 t + \phi_0)$

A *linear* sum of two waves:

$$V(t) = V_{10} \cos(\omega_{1,0} t + \phi_{1,0}) + V_{20} \cos(\omega_{2,0} t + \phi_{2,0})$$

No new frequencies are generated.

Modulation is a *non-linear process* that generates additional frequencies.

Amplitude Modulation

This is a non-linear process, where the amplitude of the signal is modulated by another signal.

$$V(t) = V_0 \left(1 + m \cos(\omega_m t + \phi_m) \right) \cos(\omega_c t + \phi_c)$$

where $0 < m < 1$ is the modulation index, ω_m and ω_c are the carrier and the modulation frequencies. The first term in the parentheses represents the carrier, and the second term the modulation. Using the trig identity

$$\cos A \cos B = \frac{1}{2} (\cos(A - B) + \cos(A + B))$$

and ignoring the phases

$$V(t) = V_0 \left[\cos(\omega_c t) + \frac{m}{2} (\cos((\omega_m - \omega_c)t) + \cos((\omega_m + \omega_c)t)) \right]$$

Three frequencies result, the carrier, and two sidebands. The carrier amplitude is unchanged, but the sideband amplitude is directly proportional to the modulation index m .

Graphical Representation of an Amplitude Modulated Signal

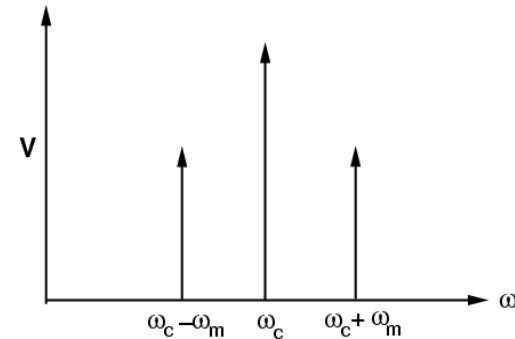
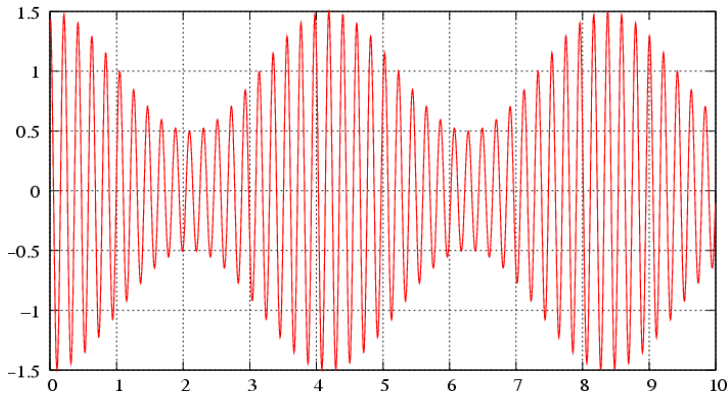

The envelope of the carrier reproduces the modulating waveform. However, the carrier itself is not changing amplitude.

The spectrum consists of the carrier and two sidebands, each separated by ω_c from the carrier frequency.

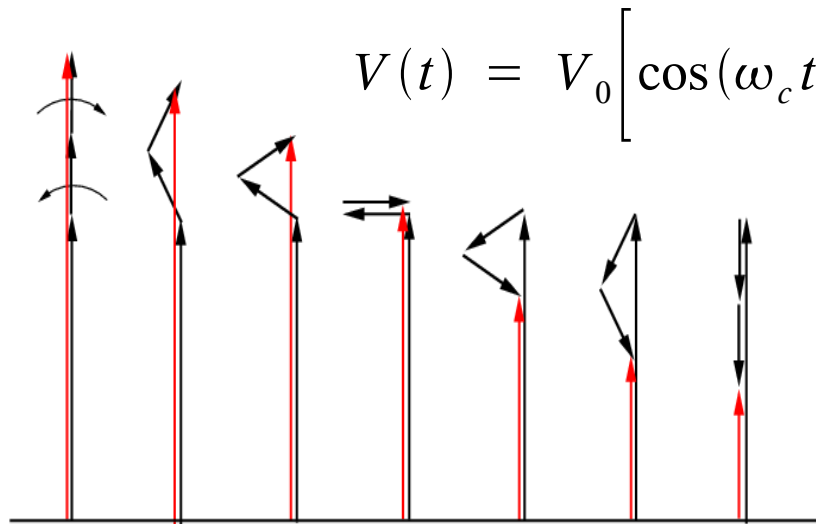

$$V(t) = V_0 \left[\cos(\omega_c t) + \frac{m}{2} (\cos((\omega_m - \omega_c)t) + \cos((\omega_m + \omega_c)t)) \right]$$

In the frame of the rotating carrier vector, the two sidebands rotate at a frequency of $+\omega_c$ and $-\omega_c$. Their vector sum (red) represents the envelope of the signal.

Can an AM signal be overmodulated?

What would the envelope look like if the carrier were eliminated? Carrier and one sideband? Is the modulation information still there?

Phase Modulation

The instantaneous carrier phase changes with the modulating waveform.

$$V(t) = V_0 \cos(\omega_c t + \Delta\phi) = V_0 \cos(\omega_c t + m \cos(\omega_m t))$$

m is the **modulation index** and ω_m is the modulating frequency.

We will use a trig identity to expand this expression:

$$\cos(A+B) = \cos A \cos B - \sin A \sin B$$

$$\frac{V(t)}{V_0} = \cos(\omega_c t) \cos(m \cos(\omega_m t)) - \sin(\omega_c t) \sin(m \cos(\omega_m t))$$

This expression is further expanded with Bessel functions:

$$\begin{aligned} \cos(z \cos \theta) &= J_0(z) + 2 \sum_{k=1}^{\infty} (-1)^k J_{2k}(z) \cos(2k\theta) \\ \sin(z \cos \theta) &= 2 \sum_{k=0}^{\infty} (-1)^k J_{2k+1}(z) \cos((2k+1)\theta) \end{aligned}$$

Phase Modulation Spectrum

The PM waveform is a double infinite series, with the carrier in quadrature to the nearest sidebands:

$$\frac{V(t)}{V_0} = \cos(\omega_c t) \left[J_0(m) + 2 \sum_{k=1}^{\infty} (-1)^k J_{2k}(m) \cos(2k\omega_m t) \right] \\ + \sin(\omega_c t) \left[2 \sum_{k=0}^{\infty} (-1)^k J_{2k+1}(m) \cos((2k+1)\omega_m t) \right]$$

The first few terms:

$$\frac{V(t)}{V_0} = J_0(m) \cos(\omega_c t) \\ + 2 J_1(m) \sin(\omega_c t) \cos(\omega_m t) \\ + 2 J_2(m) \cos(\omega_c t) \cos(2\omega_m t) \\ - 2 J_3(m) \sin(\omega_c t) \cos(3\omega_m t) \\ - 2 J_4(m) \cos(\omega_c t) \cos(4\omega_m t) \\ + 2 J_5(m) \sin(\omega_c t) \cos(5\omega_m t) \\ + 2 J_6(m) \cos(\omega_c t) \cos(6\omega_m t) + \dots$$

Phase Modulation Spectrum

Finally, we use another trig identity:

$$2 \sin A \cos B = \sin(A+B) + \sin(A-B)$$

to find

$$2 \cos A \cos B = \cos(A+B) + \cos(A-B)$$

$$\begin{aligned} \frac{V(t)}{V_0} = & J_0(m) \cos(\omega_c t) \\ & + J_1(m) [\sin(\omega_c + \omega_m) t + \sin(\omega_c - \omega_m) t] \\ & + J_2(m) [\cos(\omega_c + 2\omega_m) t + \cos(\omega_c - 2\omega_m) t] \\ & + J_3(m) [\sin(\omega_c + 3\omega_m) t + \sin(\omega_c - 3\omega_m) t] \\ & + J_4(m) [\cos(\omega_c + 4\omega_m) t + \cos(\omega_c - 4\omega_m) t] \\ & + J_5(m) [\sin(\omega_c + 5\omega_m) t + \sin(\omega_c - 5\omega_m) t] + \dots \end{aligned}$$

which shows that the sidebands separated by $n\omega_m$ have an amplitude proportional to $J_n(m)$. Note that each set of sidebands alternates in phase with respect to the carrier

Note that a modulation index $m = 2.405$ that the carrier disappears. This is the first zero of $J_0(z)$. At high modulation index, the phase of the sideband reverses.

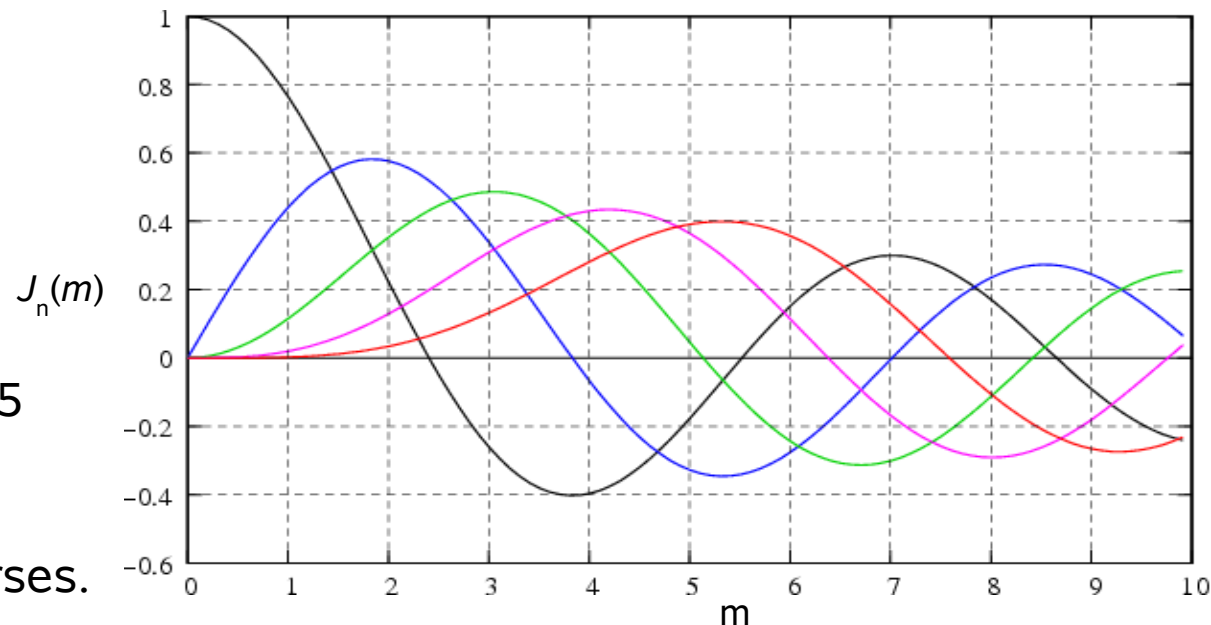

Graphical Representation of a Frequency Modulated Signal

Frequency modulation is a special case of phase modulation, where the phase shift is given by

$$\Delta \phi_{max} = \frac{\Delta f}{f_{modulation}}$$

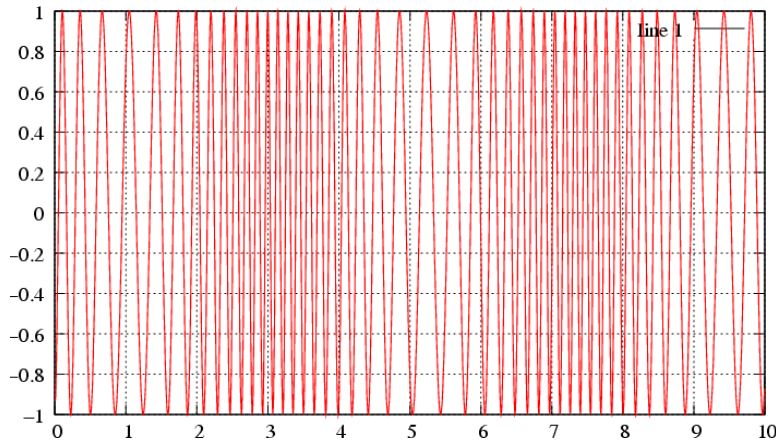

The envelope is constant, and the frequency varies with the modulation.

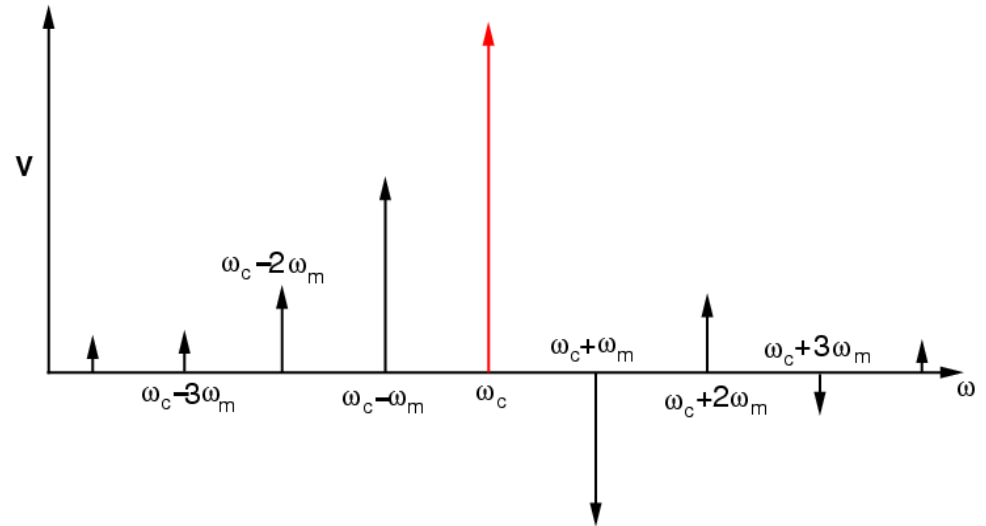

The spectrum consists of sidebands, spaced by ω_m , with phase dependent on sideband, and amplitude given by the Bessel functions.

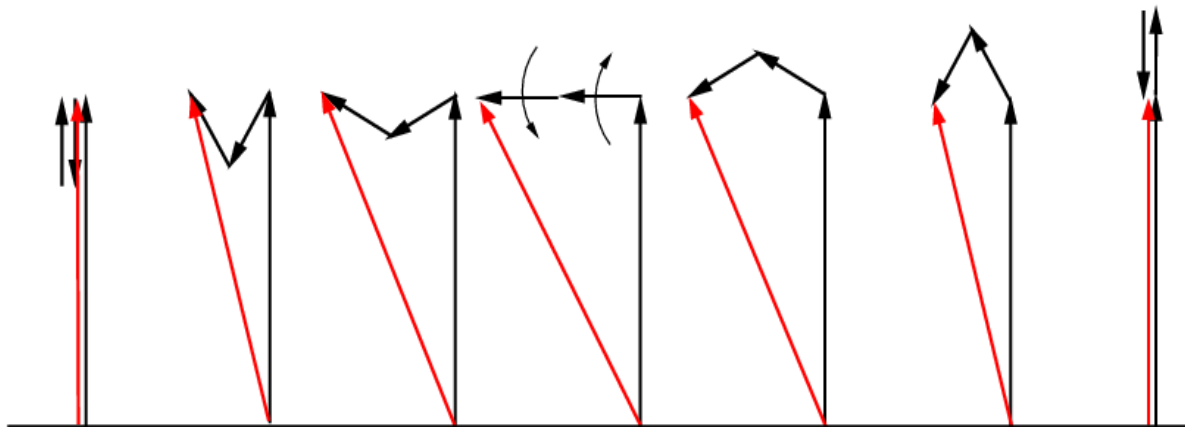

In the frame of the rotating carrier vector, the sidebands modulate the phase. Here, the carrier amplitude is not constant, but when all sidebands are included, the carrier is constant.

Can an FM/PM signal be over-modulated?

Demodulation of an Amplitude Modulated Signal

The envelope of an Amplitude Modulated signal contains the information.

Ways to recover information from an AM signal:

1. Rectify and filter out carrier
2. Synchronously detect (sample)

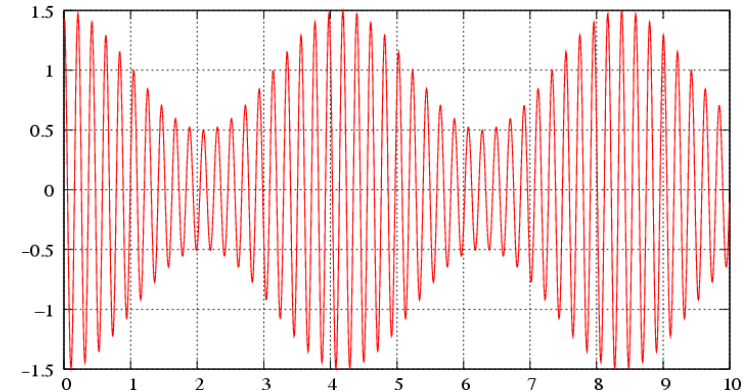

Diode detector rectifies the modulated signal and filters it with the RC integrator.

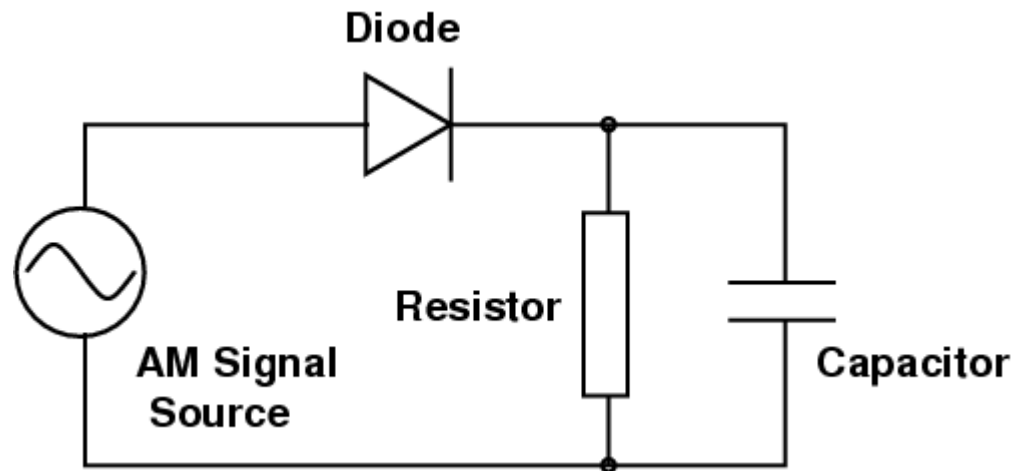

Envelope Demodulation of an Amplitude Modulated Signal

The voltage across the RC integrator approximately follows the carrier envelope of the signal.

The non-linearity of the diode and the time constant of the integrator may result in some distortion of the recovered modulation.

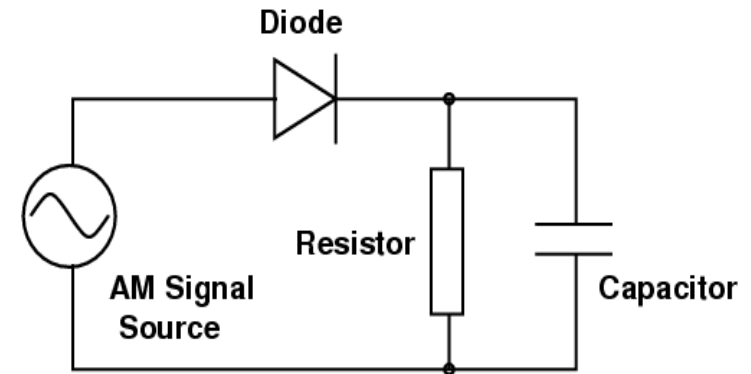

Envelope modulation does not distinguish envelope variations caused by amplitude modulation, or envelope variations caused by, for example, a frequency modulated signal passed through a filter.

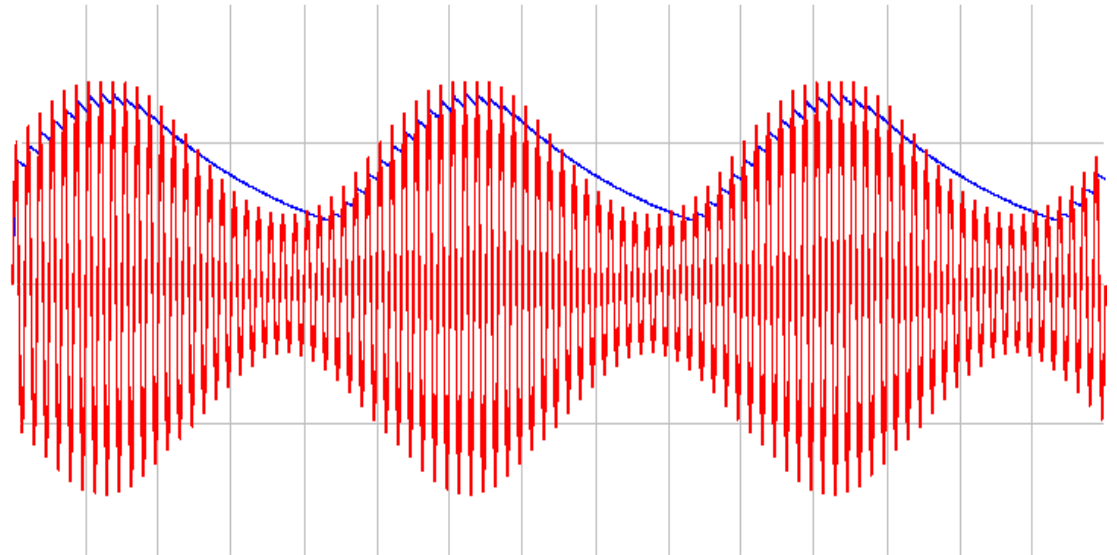

Synchronous Demodulation of an Amplitude Modulated Signal

Synchronous detection multiplies the signal with a carrier of the same frequency as the carrier of the original signal.

This way, the phase of the reinserted carrier is significant.

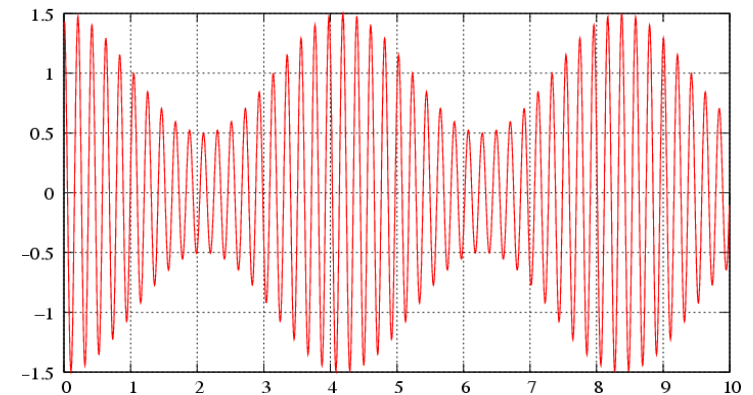

$$V(t) = V_0 \left[\cos(\omega_c t) + \frac{m}{2} (\cos((\omega_m - \omega_c)t) + \cos((\omega_m + \omega_c)t)) \right] \times \cos(\omega_c t + \phi)$$

Filter out the components with frequency $2\omega t$:

$$\frac{V(t)}{V_0} = D(t) = \frac{1}{2} \cos(-\phi) + \frac{m}{4} [\cos(\omega_m t + \phi) + \cos(-\omega_m t + \phi)]$$

Synchronous Demodulation

$$D(t) = \frac{1}{2} \cos(-\phi) + \frac{m}{4} [\cos(\omega_m t + \phi) + \cos(-\omega_m t + \phi)]$$

The recovered information depends on the phase of the reinserted carrier

In phase: $\phi = 0$ $D(t) = \frac{1}{2} + \frac{m}{2} \cos(\omega_m t)$

Quadrature: $\phi = \pi/2$ $D(t) = \cos(-\pi/2) + \frac{m}{4} [-\sin(\omega_m t) + \sin(\omega_m t)] = 0$

If the reinserted carrier is *in phase*, the recovered modulation ω_m is recovered, along with a d.c. level.

If the reinserted carrier is *in quadrature phase*, no signal is recovered.

Synchronous demodulation is *insensitive to noise in quadrature to the reinserted carrier*, and also allows two independent signals to be modulated onto one carrier frequency (e.g. color television chroma information).

Similar schemes are used for single and double sideband, suppressed-carrier communications system.

Logical Phase Detector Circuit

Logical diagram: A signal and its inverse are switched to the output at the rate $\omega_2 + \phi$.

The switching wave is call the **Local Oscillator (LO)**.

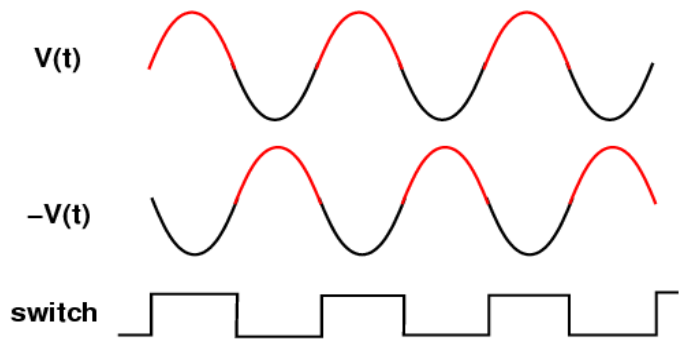
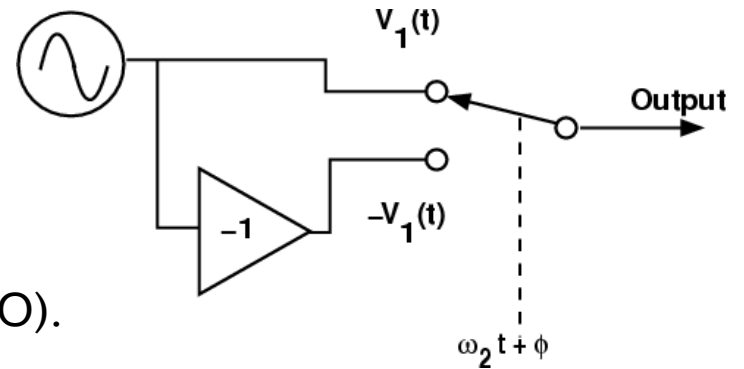

If the switching is in phase with the signal, the average output level integrates to $2/\pi$.

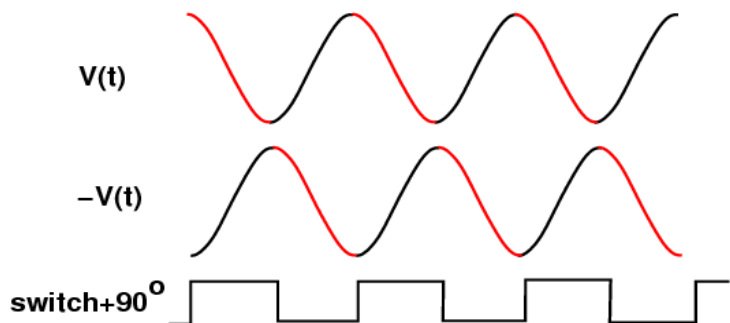

If the switching phase is advanced 90 degrees, the output integrates to zero.

What if the LO is at 180 degrees?

Practical Phase Detector Circuit

In the ideal circuit, the local oscillator (LO) performs the switching function. The signal (RF) is chopped, resulting in the Intermediate Frequency (IF) output.

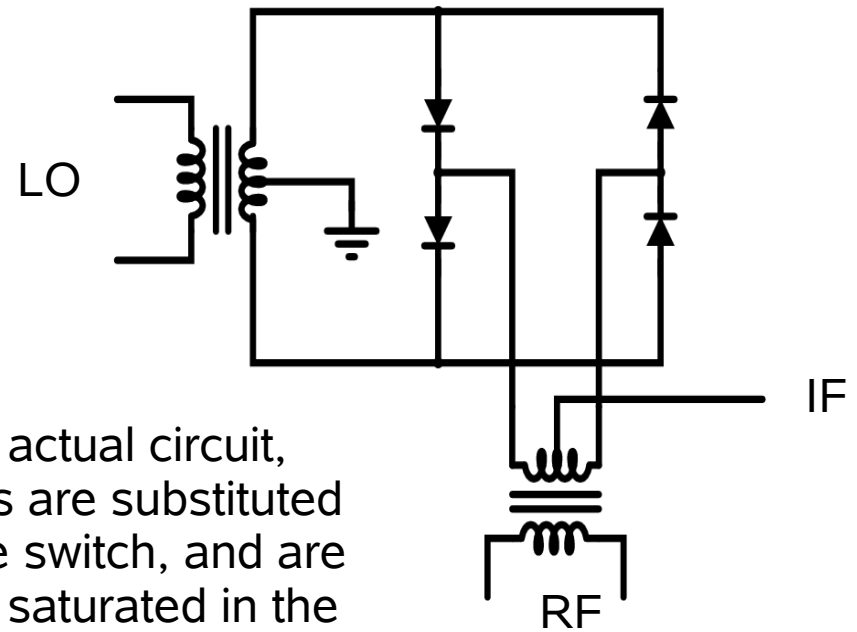
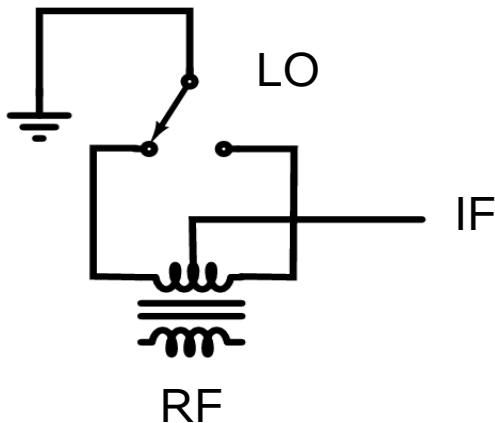

In the actual circuit, diodes are substituted for the switch, and are either saturated in the forward bias, or open in the reverse bias case.

Actual diodes are not perfect switching devices. They have a current conduction threshold which is temperature dependent. Actual mixers are usually operated with a high LO input level, saturating the diodes, and the IF output may have bias offsets due to mismatch of the diode characteristics.